

Either transformation of old equipment or installation of new equipment  
JIUKANG motor soft starter is your best selection



**SINO-U.S JOINT-VENTURE  
SHANGHAI JIUKANG ELECTRIC CO.,LTD**

Company address: No. 270, Beijing Rd (E), Shanghai

Tel: 021-63217226

Fax: 021-51901188

Technical hotline: 013588922856

**National free hotline  
800-8577630**

<http://www.jiukang.com>  
E-mail: [jiukang@mail.wzptt.zj.cn](mailto:jiukang@mail.wzptt.zj.cn)

**INTELLIGENT AC MOTOR  
SOFT STARTER**

Instructions for  
operation



**SINO-U.S JOINT-VENTURE  
SHANGHAI JIUKANG ELECTRIC CO.,LTD**

# Contents

<b>Essential information for the safety in installing</b>	.....	1
<b>Check after purchasing &amp; installation</b>	.....	2
<b>Service &amp; environment conditions</b>	.....	3
■ <b>General</b>	.....	4
■ Instruction for typical application	.....	4
■ Features & functions of LZR1 series intelligent soft starter	.....	4
■ <b>LZR1 circuit connection diagram</b>	.....	7
■ <b>Operation of soft starter</b>	.....	8
■ Instruction for soft starter display screen button	.....	8
■ Operation of soft starter	.....	9
■ External (at-different-place) button operation and setting	.....	10
■ <b>Trial run of soft starter</b>	.....	11
■ No-load trial run	.....	11
■ On-load trial run	.....	12
■ <b>Soft starter common symptom and remedy</b>	.....	13
■ <b>Fault recovery of soft starter</b>	.....	13
■ <b>Performance comparison between built-in bypass relay and external AC contactor</b>	.....	14
■ <b>Outline size of soft starter</b>	.....	14
<b>Appendix 1 Table of LZR1 soft starter kits</b>	.....	16
<b>Appendix 2 High-power motor soft starter inner delta connection drawing</b>	.....	17
<b>Appendix 3 User's trial-run records form</b>	.....	18
<b>Appendix 4 Questionnaire for users</b>	.....	19
<b>After-sale service terms</b>	.....	20

(Note: This manual is only applicable for the soft starters of 45kW or above)

## Enterprise spirit

Unite & harmonious Professional collaboration  
Scientific innovation Decisive and enterprising

## Service conception

Honest, rapid, accurate,  
high efficiency, top service

## Business philosophy

Be oriented at national and international markets,  
carry out internationalization operation

## Develop idea

Consolidate foundation, pioneer the homogeneous products,  
strive for international brand

# Instructions for operation

---

## Essential information for the safety in installing

- No layman is allowed to install and connect the soft starter;
- Never connect the power inlet lines L1, L2, L3 to output terminals U, V, W.
- Never connect the output terminals U, V, W of soft starter to the capacitor, otherwise, soft starter will be damaged easily;
- Never connect control terminals 01 and 02 of soft starter to 380V power supply;
- Never use the megohmmeter to measure the insulation resistance between the input terminals and output terminals;
- When maintaining, must switch off the circuit breaker, otherwise, the maintainer will suffer from electric shock.
- The soft starter must be earthed reliably;
- User shall not assemble, disassemble or maintain the soft starter without our consent;
- Prior to energizing and giving first trial run, must check the insulation resistance of motor and circuit, the phase-to-phase insulation resistance should be  $\geq 50M \Omega$  and to-earth insulation resistance should be  $\geq 50M \Omega$  (must switch off the motor and lead out the wires, only that, the inspection can be done).
- To ensure the safety of electric system, the circuit breaker equipped with the soft starter must be approval, the setting of over current value should be correct.

# Instructions for operation

---

## Check after purchasing and installation

- Unpacking inspection  
After unpacking the case, user shall check following items. Once finding any problem, user shall contact the supplier immediately.
- Check of nameplate: Check whether the data in the nameplate is identical with the model and specification of product purchased by you.
- Visual examination: Check whether the product is damaged in the course of transportation, such as the damage of enclosure, screen or connection terminal or the loosening of connection
- Examination of attached documents: There is a Product Certificate, Quality Warranty Card, Operation Manual provided respectively in each soft starter packing case.
- Installation:
  - Please read this Operation Manual carefully before installing
  - Installation tool: Screwdriver (the large size and small size for each), wire stripper, four M8 bolts; eight  $\phi 8$  plain washers and four  $\phi 8$  spring washers.
- Connection: After fixing the soft starter, connect the wires correctly according to the connection drawing 1. During connecting, must see the connection terminal number in the soft starter clearly, and prevent the wrong connection of terminal.

# Instructions for operation

---

## Service & environment conditions

- Power supply of main circuit: Three-phase 380V(-10%+15%) 50Hz±0.2%;
- Control circuit power: 220V, 50Hz;
- Applicable motor: Common squirrel-cage motor (negotiate with the manufacturer if need wound motor and synchronous motor)
- Frequency of starting: It is suggested that the frequency of start and stop should be 12 times per hour at most, and the interval for every start and stop should be 5min at least.
- Cooling way: Natural air cooling or fan cooling by turning on the machine (the switch is on the enclosure), when the machine inner temperature exceeds 45°C, the fan runs automatically.
- Installation way: Fixed with 35mm rail or bolt
- Protection degree: IP20~IP30, determined by power grade
- Environment condition: When the altitude is over 3000m, the capacity is derated correspondingly.
- Environment temperature: -25~+40°C
- Relative humidity should not exceed 95%( at 20°C~65°C);
- No condensation, corrosive gas or conductive dust
- Installed indoors or installed in the cabinet outdoors, and the installation site should be quite ventilated.
- The shock force shall be less than 0.5g.

# Instructions for operation

---

## ■ General

Motor soft starter is a voltage step-down starter that rises quietly in the vigorous development electric and electronic technology, and now, it is the most advanced and popular AC motor starter following the Y/Δ starter, auto-coupling step-down starter, magnetic control starter. As the starter development history shows, there was Generation I online products and Generation II external bypass products, and LZR1 series soft starter selects the advantages of Generation I and II products, and eliminates their disadvantages, its original high-power inner bypass technology (running current reaching as high as 1000A), opens a new field to Generation III soft starters.

JUKANG LZR1 series intelligent soft starter is an only patent product that uses built-in bypass technology of domestic high-power soft starters.

### ■ Instruction for typical application

- Water pump: With the soft stop function of soft starter, the water hammer effect as a result of high hydraulic pressure can be eliminated effectively when the water pump stops.
- Fan: The smooth movement of soft starter brings the less belt abrasion and mechanical impact and is helpful for prolonging the service life of equipment.
- Conveying machinery: The smooth and gradual start of soft starter can take effect on avoiding the product displacement or material overflow.
- LZR1 series intelligent soft starter has following features and functions:
  - Three starting ways
    - The voltage slope starting way brings the max starting torque for the motor.
    - The constant current limited current way can restrict the motor starting current to the utmost extent.
    - The pulse-jump starting way is quite applicable for the start of the heavy-duty equipment.
  - Stop way: Voltage ramp soft stop (select the soft stop time according to the demands)
  - Multi-protection function: Protection against the phase failure, over current and over load.

# Instructions for operation

- Programmable interlock control, fault memory output: When the fault of motor or circuit occurs, the system switches off the main circuit automatically after receiving the order sent by the PC machine, the starter is in the state of waiting due to failure, and the start control is locked for waiting the disposal of failure.
- Chinese characters display function: Friendly human-machine interface and LCD display, which display kinds of set starting parameters and running state of soft starter in visual.
- Built-in bypass patent technology (patent number: ZL200620044145.2) has following highlights:
  - It is very simple to connect the main circuit, needless to install an extra bypass AC contactor, therefore to take more convenience in installing and connecting the soft starter and bring the high efficiency and economy in installation cost.
  - By using this technology, the soft starter is more compact and it is very convenient in assembly.
  - Due to electronic arc-extinguishing technology, the contact on-off operation doesn't produce the electric arc, to solve the long-term nasty problems of AC contactor, accordingly, it improves the reliability of system and prolongs the electric life of contact, (the contact electric life is equal to its mechanical life).
  - Obvious energy-saving features: 1. the bypass relay only takes 2 minutes to energize when making and breaking, and in other time, it is in the no-power operation state; 2. its contact DC resistance is only  $0.5\text{m}\Omega$  (and the contact DC resistance of AC contactor is about  $100\text{m}\Omega$ ), so, the built-in bypass device is obvious in energy saving, and doesn't take any electromagnetic pollution. In light of these, the built-in bypass soft starter will be popular with customers.
- Control at different places: Achieve the conversion between the soft starter key board-control start and at-different-place (remote) button-control start in available. And interlocking is realized between the keyboard-control start and at-different-place control start, due to this function, the starter is especially used for the required starting equipment in the harsh equipment.
- Light-load energy-saving function: When the motor runs from the heavy load operation state to the light load operation state, the soft starter will reduce the output voltage automatically, to further lowering the motor operation current. This function can reduce the consumption of copper and iron, improve the power factor, therefore, it takes effect on saving energy. (Please give a particular indication when ordering).
- Automatic cooling function: When the soft starter inner temperature exceeds  $45^{\circ}\text{C}$ , the fan can turn on automatically to cool down.

# Instructions for operation

## ■ LZR1 main circuit connection drawing

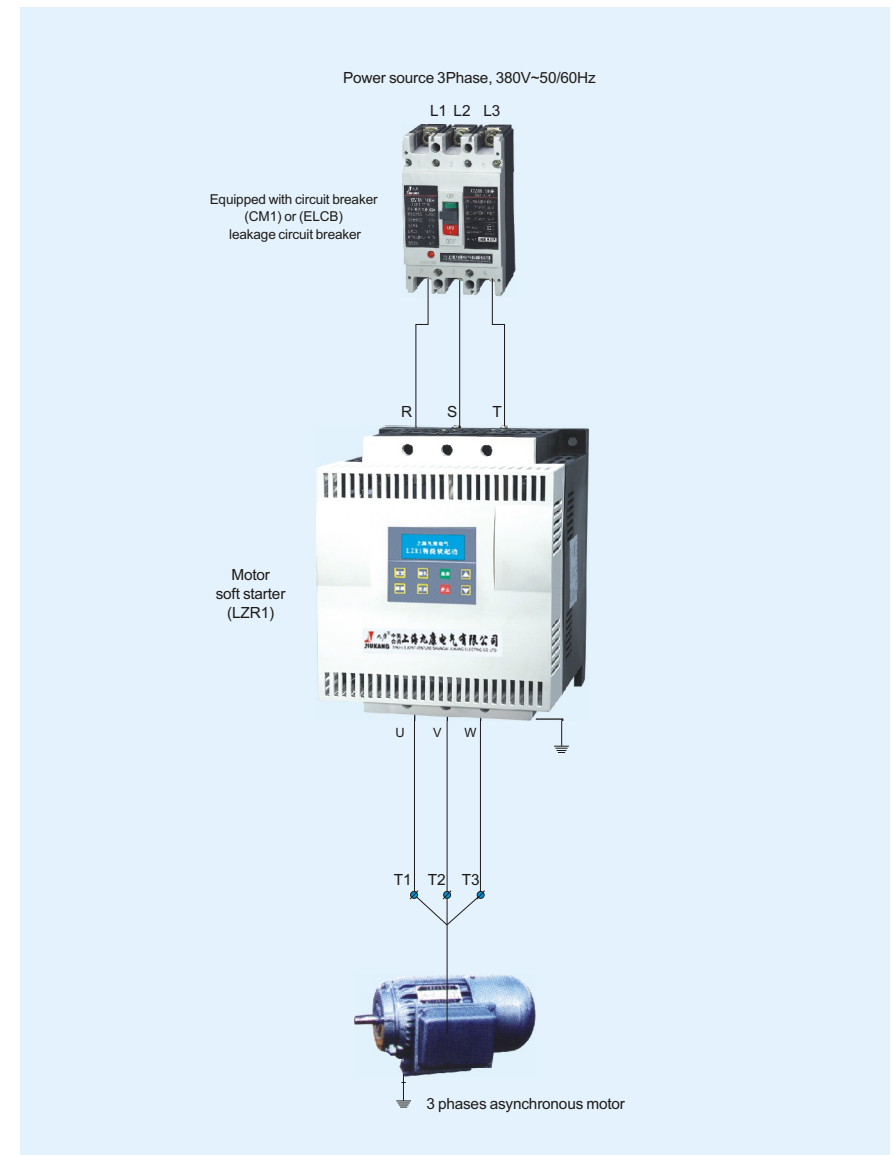

# Instructions for operation

## ■ Circuit connection drawing (Standard drawing)

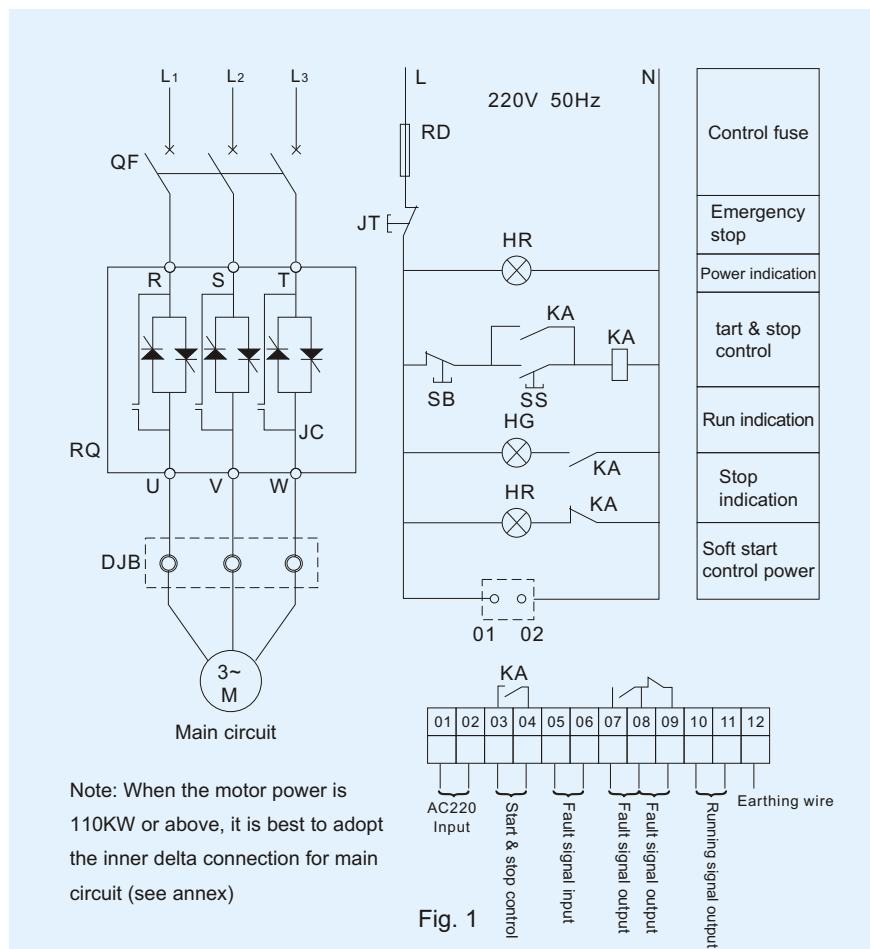

## ■ Soft starter main circuit connection

The power lines L1, L2 and L3 are connected to the soft starter input terminals R, S, T; and the soft starter output terminals U, V, W are directly connected to motor.

The connection of the input terminals R, S, T and output terminals U, V, W must be correct!

# Instructions for operation

## ■ Soft starter control circuit connection

- No. 1 terminal is connected to control power phase line (L);
- No. 02 terminal is connected to the power neutral line (N);
- No. 03 and 04 terminals are the start and stop control terminals (start after they are switched on, and stop after they are switched off) are connected to the NO contact of intermediate relay.
- No. 05 and 06 terminals are the fault input signal terminal (input the make fault signal, after both of them are switched on, the main circuit power is cut off, the start control is locked);
- No. 07 and 08 terminals are the fault output signal terminal (when the circuit breaks down like the over load, both of them closes).
- No. 08 and 09 terminals are the fault output signal terminal (when the circuit breaks down like the over load, both of them opens).
- No. 10 and 11 terminals are the operation output terminal (after the soft start operation ends, and the bypass relay closes, both of them closes, and during soft stop, both of them opens).
- No. 12 terminal is the protective earth terminal

## ■ Operation of soft starter

### ■ Instruction for soft starter display screen button

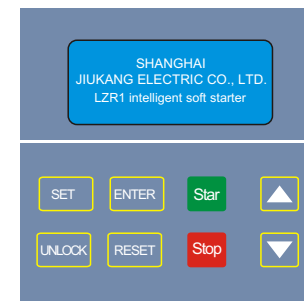

# Instructions for operation

- SET** SET key for starting parameters: Set the starting parameters by pressing this key.
- UNLOCK** UNLOCK key for parameters setting: Press this key first, then set the starting parameters by pressing the set key.
- ENTER** ENTER key for parameter setting: after ending the setting of each starting parameter, confirm the set parameters by pressing this key.
- RESET** RESET key for initial parameters: After pressing the unlock key, then, push down this key, the soft starter starting parameters resumes the ex-factory setting values.
- Star** Keyboard start control key: Press this key, the soft start begins.
- Stop** Keyboard stop control key: Press this key, the soft stop begins.
- ▲** UP key for starting parameters: Change the parameter or increase the value by pressing this key
- ▼** DOWN key for starting parameters: Change the parameter or decrease the value by pressing this key

## ■ Soft starter operation methods

- Set the starting parameters
- Make sure the soft starter connection is correct according to figure 1, then switch on the circuit breaker QF, the soft starter LCD brightens, it displays

JIUKANG Electric  
LZR Intelligent Soft Starter

After 3s, LCD displays the following information:

Current state: Stop  
Starting way: Slope

- Press the **UNLOCK** key first, then the **SET** key, the display as follows: The character ramp flickers in the LCD.

Current state: Set  
Starting way: Slope

- Press the key **▲** or **▼** to select the Ramp, jump, current limiting , then press the **ENTER** key to confirm, the LCD displays as follows: The digit flickers in the LCD.

Current state: Set  
Starting time: 150s

# Instructions for operation

- Press the key **▲** or **▼** to select the suitable starting time, then press the **ENTER** key to confirm, the LCD displays as follows: The digit flickers in the LCD.

Current state: Set  
Starting voltage: 150V

- Press the key **▲** or **▼** to select the suitable voltage, then press the **ENTER** key to confirm, the LCD displays as follows: The digit flickers in the LCD.

Current state: Set  
Soft start time: 05s

- Press the key **▲** or **▼** to select the suitable soft stop time, then press the **ENTER** key to confirm, the LCD displays as follows: The digit flickers in the LCD.

Current state: Set  
Rated current: 90A

- Press the key **▲** or **▼** to select the suitable rated current, then press the **ENTER** key to confirm, LCD displays as follows: The digit flickers in the LCD.

Current state: Set  
Setting value of sensor: 300A

- Press the key **▲** or **▼** to select the suitable current (see table 1), then press the **ENTER** key to confirm, the LCD displays as follows: The digit flickers in the LCD.

Current state: Stop  
Starting way: Slope

- External (at-different-place) button operation and setting

- Before the soft starter control power is energized, press the **SET** key and **UNLOCK** key simultaneously, then switch on the control power, LCD displays following information: The character **OFF** flickers in the LCD.

System setting:  
External button: Off

# Instructions for operation

- Press the key or to select **NO** first, then press the **ENTER** key to confirm, the LCD displays as follows:

Current state: Stop  
Starting way: Slope

The character stops flickering in the LCD. Once this setting is finished, the keys **Start** and **Stop** on the keyboard of soft starter will be locked without working, the stop and stop of soft starter is controlled only with the external button. (If wanting to resume the keyboard control, set the external button to OFF, the method is the same as item (1).

- Table of sensor value setting

Table1

Soft starter Power (KW)	Sensor set value	Soft starter Power (KW)	Sensor set value	Soft starter Power (KW)	Sensor set value
45	300A	110	700A	250	1600A
55	350A	132	800A	320	2000A
75	500A	160	1000A	400	2500A
90	600A	200	1200A	500	3000A

- Adjustable range for setting the starting parameters of LZR1 soft starter

Table2

Starting way	Initial voltage	Starting time	Soft starting time
Slope, jump, current limiting	100V~300V	5S~60S	0~60S

## Trial run of soft starter

- No-load trial run

Switch on the control power of soft starter (no current passing through main circuit), and set the starting parameters, later, press the **Start** key or external starting button SS, the soft starter actuates in the way of soft start according to the set starting parameters, LCD displays following information:

In starting  
10S

After soft starting, the soft starter built-in bypass relay closes, and the soft starting operation ends. The LCD displays as follows:

Current state: Run  
Starting way: Slope

# Instructions for operation

Display after 3s:

System exception

Because there is no current passing through the main circuit (phase failure state), LCD displays system exception after the protection of soft starter functions. In addition, when the motor rated current is set improperly, LCD also displays the system exception.

- On-load trial run

After finishing the no-load trial run, as shown in figure, connect one bulb (not less than 300W) to the soft starter output terminals U, V, W respectively, press the START key to start the soft starter, these lamps will give little light to much light, then, they give the stable light to most light, this indicates that soft starter is normal in soft starting; press STOP key, these lamps will give the much light to little light, till it goes out, this indicates that the soft starter is normal in soft stop.



- Selection of soft starter starting parameters (only for reference)

Table 3

Machinery type	Load type	Starting way		Value setting		Soft starting time	Remark
		Voltage	Current	Voltage	Current		
Water pump	Standard load	Slope		150V		15S	
Air compressor	Standard load	Slope		150V		10S	
Belt conveyor	Standard load	Slope		170V		25S	
Agitator	Standard load	Slope		150V		25S	
Crusher	Standard load	Slope		150V		20S	
Ball mill	Heavy load	Jump		170V		25S	★
Fan	Heavy load	Slope		170V		35S	

If the power is supplied by the self-contained generator, you had better use the limited current starting way for the motor starting.

★ You shall make use of our designed connection drawing.

# Instructions for operation

## Common faults and eliminations of soft starter

Table4

Fault symptom	Cause	Measures
Display screen does not go on	1、 01 and 02 terminals are wrong wired or have not been electrified; 2、 Fuse wire is burnt out; 3、 The emergency stop button is pushed down; 4、 There is something wrong with the display screen.	1、 Check the wiring of 01 and 02 terminals and check if they have been electrified; 2、 Check and change the fuse wire; 3、 Reset the emergency stop button; 4、 Return back to the factory for changing.
Refuse to start	1、 Start up control is external button controlled; 2、 03 and 04 are wrong wired; 3、 Intermediate relay does not work, or 08 and 09 are disconnected; 4、 There is something wrong with the soft starter.	1、 Change the starting control into keyboard control, or make use of the external button to start; 2、 Check the wiring of 03 and 04; 3、 Check if the 08 and 09 have been put through, change the button or intermediate relay; 4、 Change the soft starter.
Start directly	1、 Starting voltage is too high; 2、 Starting time is too short; 3、 Bypass conduction; 4、 Module conduction.	1、 Lower the starting voltage; 2、 Prolong the starting time; 3、 No-load start, operate and stop for one time; 4、 Return back to the factory for changing.
Display system is abnormal after starting	No load current or the load current is too low.	Just put through normal loads.

## Fault recovery of soft starter

When the motor comes across overload or over-current during operation, protection function of soft starter will bring into play, its liquid crystal screen will indicate the system anomaly or motor overload, starting control of soft starter will be locked, at this moment, neither the keyboard starting control nor the external button starting control is effective, the soft starter can resume normal operation state (the former set parameter will not be changed) only by cutting off its control power source and electrifying it again.

Remark: The faults should be fully eliminated first once the motor comes across any trouble, breaking and making the control power supply of soft starter may restore the starting function for the moment, but it may aggravate the faults, meanwhile, the soft starter will make the protection operation again in short time and display the system anomaly or motor overload again!

# Instructions for operation

## Performance comparison between built-in bypass relay and external AC contactor

eg.: Rated current of three-phase motor of 50KW is 100A (the actual value is a little smaller, for convenience of calculation) Power consumption= $I^2 \times R$  (square of current value  $\times$  numerical value of resistance)

## Built-in bypass relay VS AC contactor

Table5

Name	Built-in bypass relay	AC contactor
Volume	Small, occupies little space	Large, occupies some space
DC resistance of contact	Small, 0.5m $\Omega$	Large, 100m $\Omega$
Coil operation	Only need to be electrified for 2s DC12V	Long term electrifying>100W AC220V or 380V
Noise	No	Yes
Electromagnetic pollution	No	Yes
Power consumption	0.36 degree/24h	72 degree/24h

## Outline and mounting size

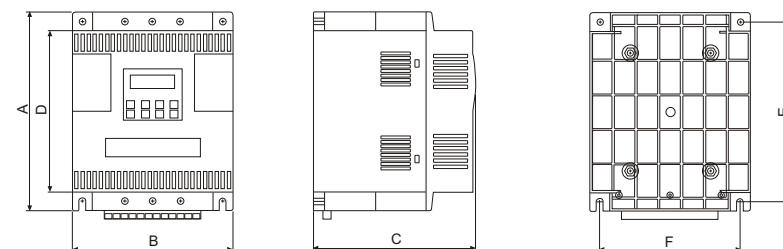

Spec. & model	Power (KW)	Rated current (A)	Outline				Mounting size		Mounting aperture	Weight (kg)
			A	B	C	D	E	F		
LZR1-45	45	90	270	220	227	220	245	192.5	$\Phi 9$	5.5
LZR1-55	55	110	270	220	227	220	245	192.5	$\Phi 9$	8.5
LZR1-75	75	150	270	220	227	220	245	192.5	$\Phi 9$	8.5
LZR1-90	90	180	270	220	227	220	245	192.5	$\Phi 9$	9
LZR1-110	110	220	270	220	227	220	245	192.5	$\Phi 9$	9

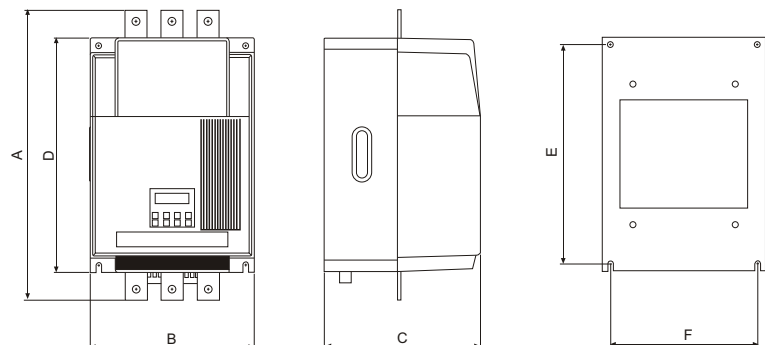

Spec. & model	Power (KW)	Rated current (A)	Outline				Mounting size		Mounting aperture	Weight (kg)
			A	B	C	D	E	F		
LZR1-132	132	264	520	295	280	420	480	265	Φ 10	30
LZR1-160	160	320	520	295	280	420	480	265	Φ 10	30
LZR1-200	200	400	520	295	280	420	480	265	Φ 10	30
LZR1-250	250	500	520	295	280	420	480	265	Φ 10	30

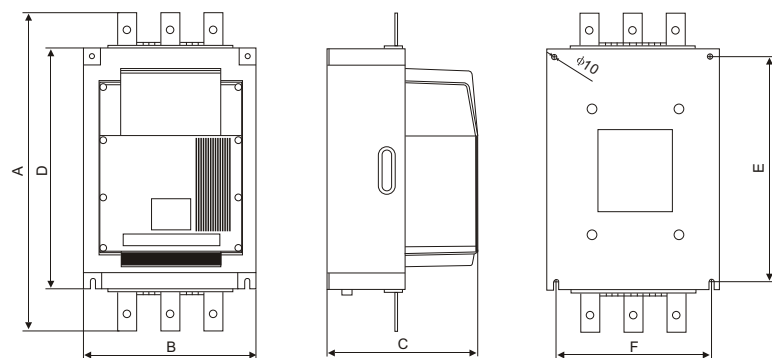

Spec. & model	Power (KW)	Rated current (A)	Outline				Mounting size		Mounting aperture	Weight (kg)
			A	B	C	D	E	F		
LZR1-320	320	640	680	360	315	510	483	325	Φ 10	40
LZR1-400	400	800	680	360	315	510	483	325	Φ 10	40

### Table of LZR1 soft starter kits

Power (KW)	Current (A)	Model & spec. Of soft starter	Model & spec. Of circuit breaker	Model & spec. Of motor protector	Setting value of over-current protection(A)	Wire size mm <sup>2</sup>
45	90	LZR1-45	CDM1-225/3300	JDG1-120	104	25
55	110	LZR1-55	CDM1-225/3300	JDG1-600	127	35
75	150	LZR1-55	CDM1-225/3300	JDG1-600	173	35
90	180	LZR1-90	CDM1-400/3300	JDG1-600	207	50
110	220	LZR1-110	CDM1-400/3300	JDG1-600	253	75
132	264	LZR1-132	CDM1-400/3300	JDG1-600	304	75
160	320	LZR1-160	CDM1-400/3300	JDG1-600	368	95
200	400	LZR1-400	CDM1-630/3300	JDG1-600	460	95
250	500	LZR1-250	CDM1-630/3300	JDG1-600	575	75 × 2
320	640	LZR1-320	CDM1-800/3300		736	95 × 2
400	800	LZR1-400	CDM1-1250/3300		920	95 × 2

#### ■ Description

- Elements and data in this table are only for reference, users please select according to the actual loading conditions.
- Motor protector is unnecessary when the soft starters of 45KW and above work in way of one drives one, and it requires the motor protector when it is one drives N (1 < N ≤ 5).

## Appendix 2

### High-power motor soft starter inner delta connection drawing

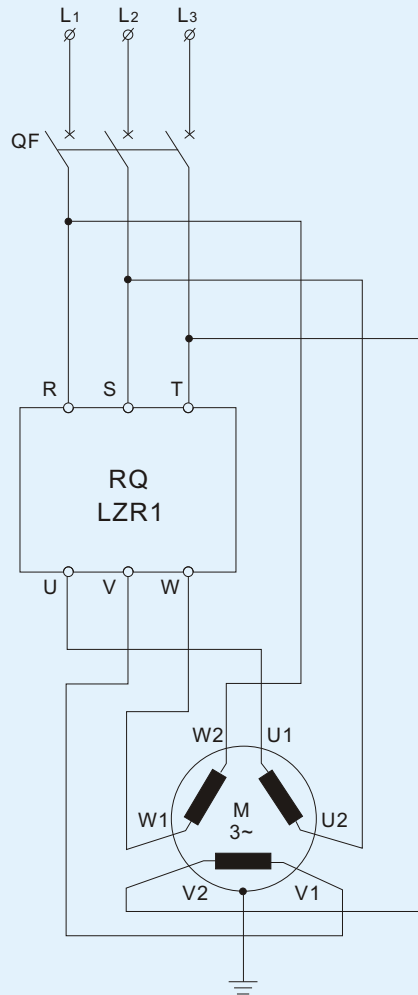

Main loop connection diagram of 110KW above  
Soft starter is connected in the motor winding in series

## Appendix 3

### User's trial-run records form

Spec. & model		Product code	
Type of load	Fan, water pump		
Starting parameter setting for the first time			
Starting mode	Slope	Jump	Current limiting
Starting voltage	(V)	Starting time	(S)
Rated current	(A)	Transformer	(A)
Starting test running for the first time			
Max starting current	(A)	Max current/rated current	Times
Starting parameter setting for the second time			
Starting mode	Slope	Jump	Current limiting
Starting voltage	(V)	Starting time	(S)
Rated current	(A)	Transformer	(A)
Starting test running for the second time			
Max starting current	(A)	Max current/rated current	Times
Date of test running	Tested by		

## Questionnaire for users

Name of user		Contact	
Address		Contact phone	
Spec. & model	Number	Type of load	Fan, water pump
Date of acquisition	Date of mounting	Date of test running	
Questionnaire for users	1	Where did you get the information of Jiukang soft starter? <input type="checkbox"/> Dealer <input type="checkbox"/> Advertisement <input type="checkbox"/> Other	
	2	How do you think about the functions of product? <input type="checkbox"/> Complete <input type="checkbox"/> Defective <input type="checkbox"/> Need to be improved	
	3	How do you think about the price of product? <input type="checkbox"/> Reasonable <input type="checkbox"/> Too expensive <input type="checkbox"/> Rather cheap	
	4	How do you think about the contour design of product? <input type="checkbox"/> Beautiful <input type="checkbox"/> Ordinary <input type="checkbox"/> Need to be improved	
	5	How do you think about the package of product? <input type="checkbox"/> Beautiful <input type="checkbox"/> Ordinary <input type="checkbox"/> Need to be improved	
	6	How do you think about the built-in bypass function of product? <input type="checkbox"/> Very practical <input type="checkbox"/> Unpractical	
	7	How do you think about our sales service? <input type="checkbox"/> Very satisfactory <input type="checkbox"/> Satisfactory <input type="checkbox"/> Dissatisfactory	
	8	How do you think about our technical service? <input type="checkbox"/> Very satisfactory <input type="checkbox"/> Satisfactory <input type="checkbox"/> Dissatisfactory	
	9	What do you value most about the product? <input type="checkbox"/> Functions <input type="checkbox"/> Price <input type="checkbox"/> Contour <input type="checkbox"/> Service	
	10	Which part do you think is highly required for improving? <input type="checkbox"/> Functions <input type="checkbox"/> Contour	
Is there any suggestion or opinion on our products or service?			
1			
2			
3			
4			
5			
Remark: Please ask the dealer to pass on this list to the company or send by post to the technology department of the company directly.			

## After-sale service item

"Three Guarantees" of Jiukang brand intelligent AC motor soft starters shall remain in force for one year since the date of purchase, free service is available from Shanghai Jiukang Electric Co, Ltd. for quality problem of soft starter within this period. When beyond this period, repair cost also is free, but ask for reasonable fittings cost.

## "Three Guarantees" service item

- Conditions for "Three Guarantees" service.
- The products must be purchased from Shanghai Jiukang Electric Co, Ltd. or from the authorized dealers or agents;
- The Warranty Card must be sealed and confirmed by Shanghai Jiukang Electric Co, Ltd. or the authorized dealers or agents;
- Conditions for "Three Guarantee" products: Intact appearance, label and mark, complete fittings

## "Three Guarantees" service will not be prepared for the following products

- Soft starters that are damaged due to improper mounting or wiring;
- Soft starters that are damaged due to improper operation or maintaining;
- Soft starters that are damaged due to disassembling or refitting without authorization;
- Soft starters that are viciously altered or lack of label or fittings, or the fittings are damaged;
- Soft starters that are damaged due to force majeure or natural calamities.

Please properly keep the Operating Manual, Warranty Card and Purchase Invoice.